

MXYZR :: XYZR BOOMERAX MANIPULATOR SERIES

This configuration example provides every necessary degree of freedom for full control over your samples in a UHV environment and sample temperatures down to 10 Kelvin by combining a "Boomerax" high precision XY stage with our MZ linear Z-axis drive and incorporating a well-established and very stable Janis ST-400 continuous flow cryostat.

Boomerax MXY module :: For smooth and exceptionally precise adjustment, it offers a resolution of 2 microns when manually driven and even higher resolutions when motorized.

MZ Z-Translator :: The optionally motorized linear Z-axis drive comes into play for accurate lifting and lowering. It's highest quality edge welded bellows fulfill the strictest requirements in terms of leak tightness and durability.

ST-400 He-Flow Cryostat :: As one of the the simplest methods of providing cooling in an ultra-high vacuum environment, the ST-400 has several features that are specific for UHV requirements.

MR63DPV552 Rotary Feedthrough :: This differentially pumped rotating platform provides the means of translating rotation through a vessel wall without losing vacuum integrity

Sample Environment :: The tiltable sample stage is equipped with a RECOMEC13 receiver for sample plates with electrical contacts, giving a further degree of freedom and the possibility of wiring up various measurement devices.

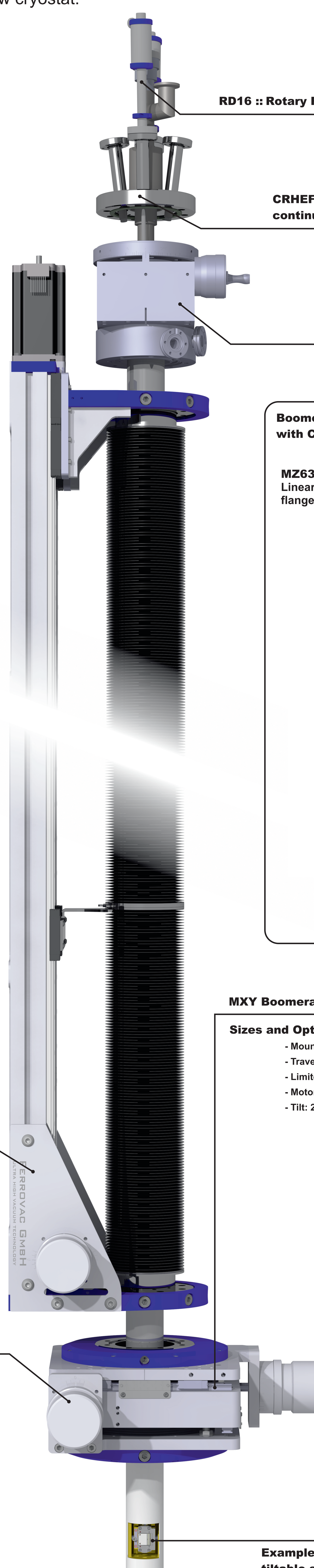

RD16 :: Rotary Feedthrough DN16CF

CRHEFJRST400UHV :: Model ST-400 UHV, LHe or LN₂ continuous flow cryostat system with sample in vacuum

MR63DPV552 :: Differentially Pumped Rotary Feedthrough

Free Bore

As the supports of the bellows are mounted externally, the bellows has a continuous free bore from top to bottom

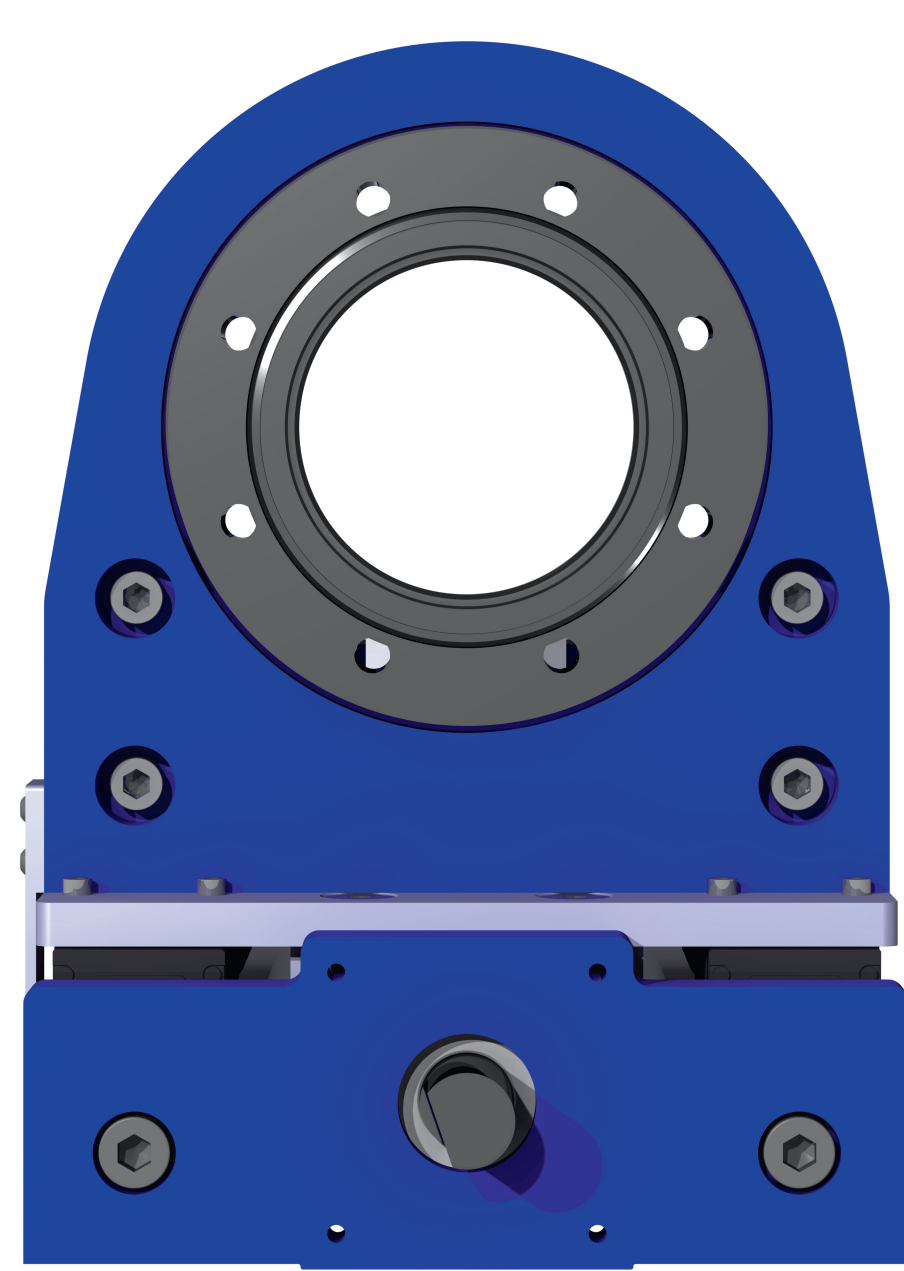

Slide Bearing for Guidance

To hold and guide the mounted cryostat especially during linear adjustment, a slide bearing sits inside the mounting flange.

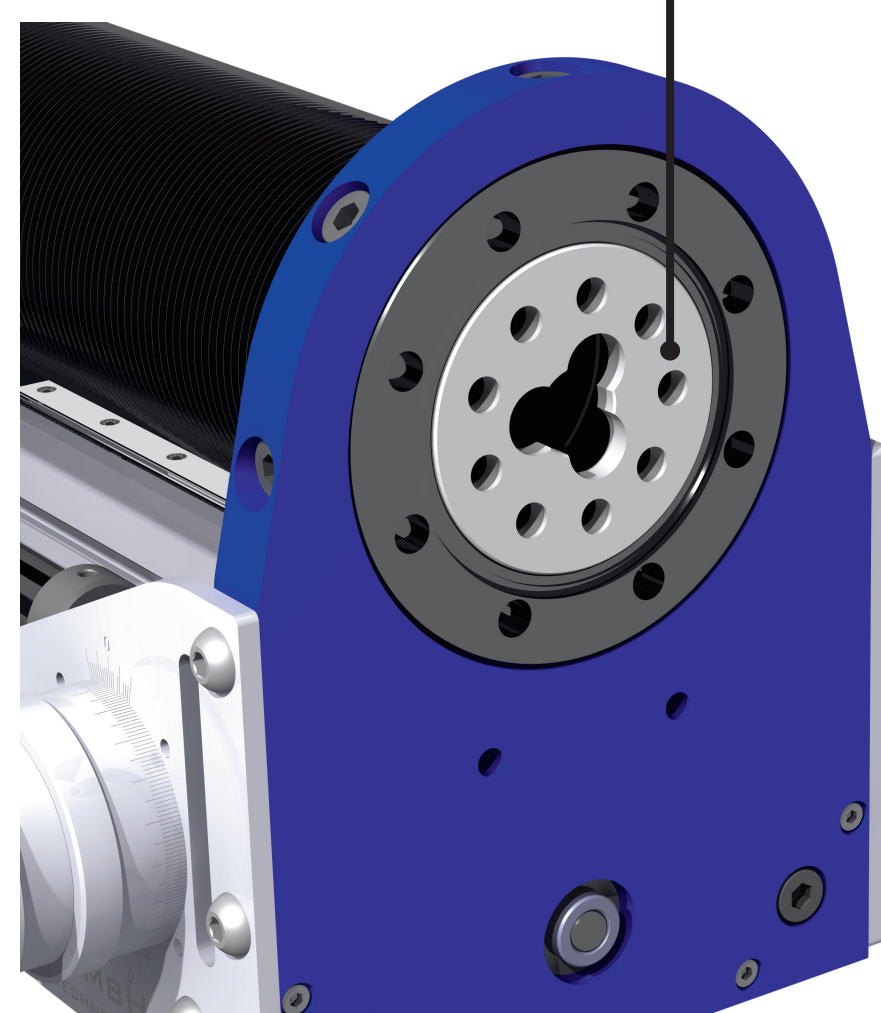

MZ Motorized Linear Z-Drive

Sizes and Options

- Flange Sizes: DN40CF, DN63CF, DN100CF
- Standard Linear Travel Lengths: 100, 200, 300, 400, 500, 750, 1000, 1250mm
- Adjustable Position/Limit Switch
- Linear Encoder
- Tapped or Through Holes for Either or Both Flanges

Manual or Motorised Actuation Alternatives

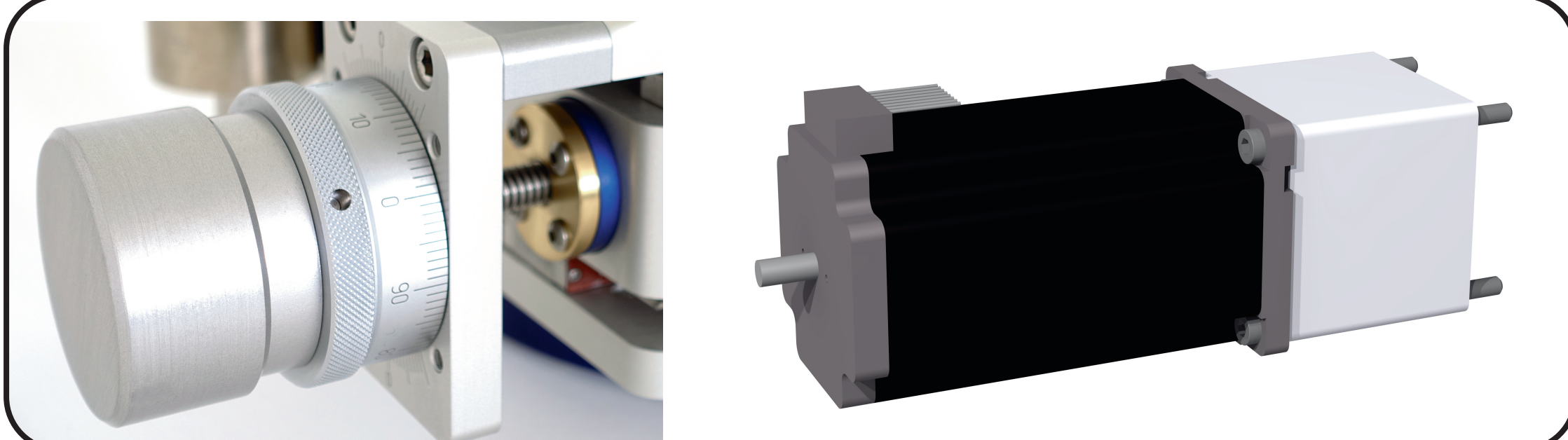

Boomerax XYZ Stage with Chamber for Electrical Feedthroughs

MZ63CH63CF63-0100 :: Linear Z-Drive with two DN63CF flanges and 100mm of travel

MZFCHCF63TCF63T5XCF16T Compact mounting chamber for electrical feedthroughs

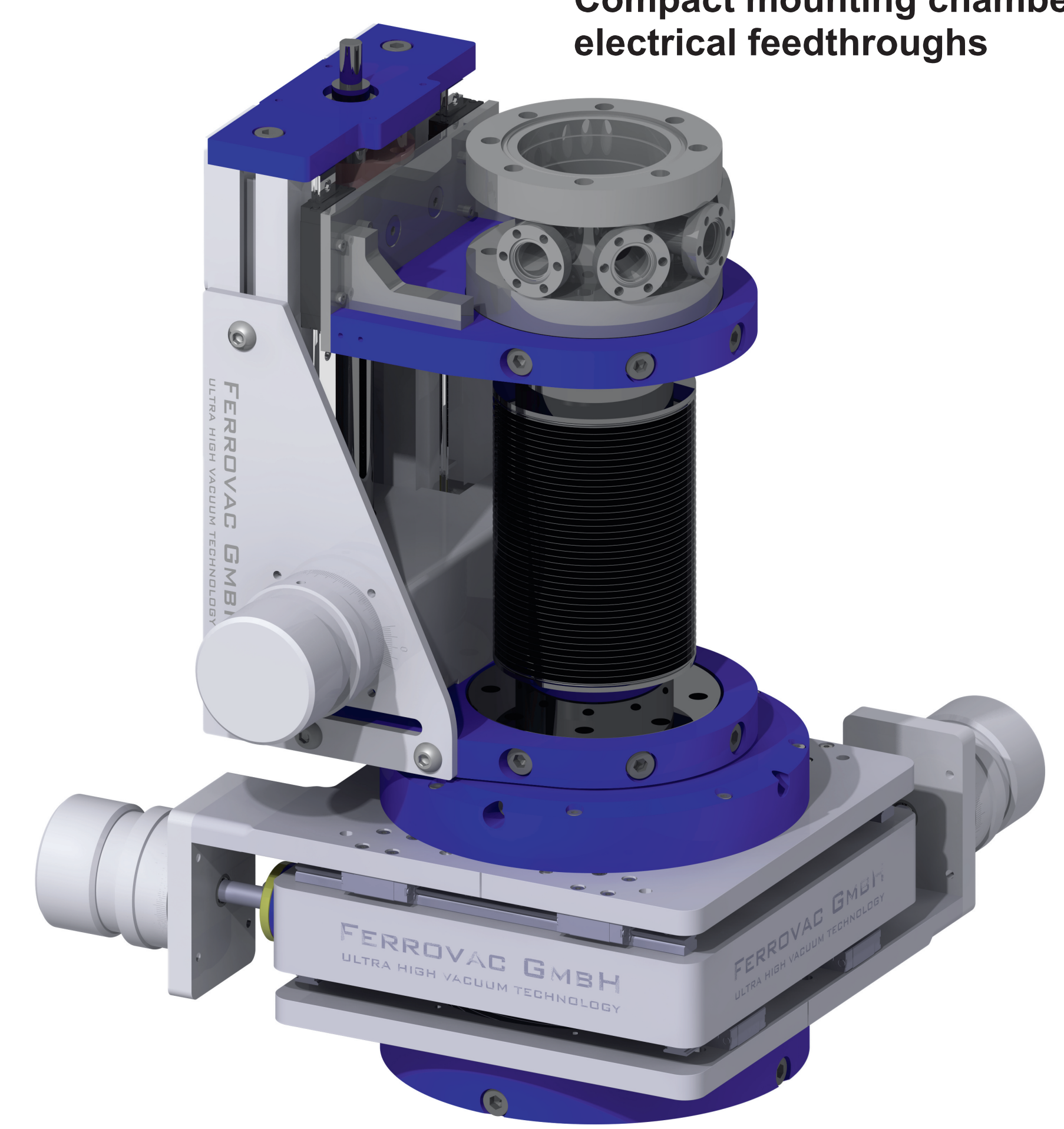

MXY100CF100TCF63TXY :: Boomerax High Precision XY Stage with +25mm and +12.5mm XY travel and bellows ID=100mm

MXY Boomerax XY Stage

Sizes and Options

- Mounting Flange Sizes: DN16CF, DN40CF, DN63CF, DN100CF, DN160CF
- Travelling Flange Sizes: DN16CF, DN40CF, DN63CF, DN100CF, DN160CF
- Limiteable Travel Distances
- Motorization Options Available for All Sizes
- Tilt: 2° in Any Desired Axis

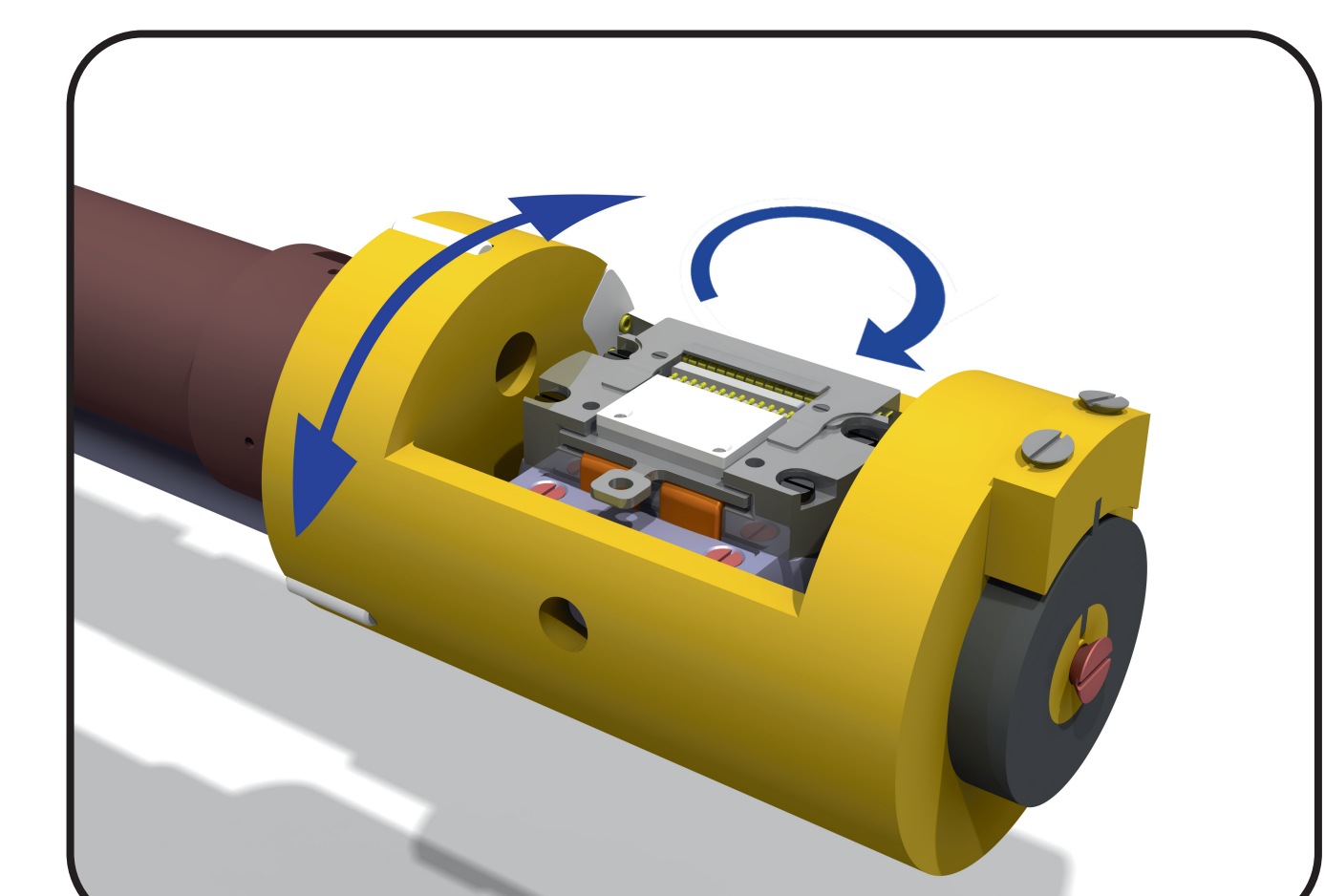
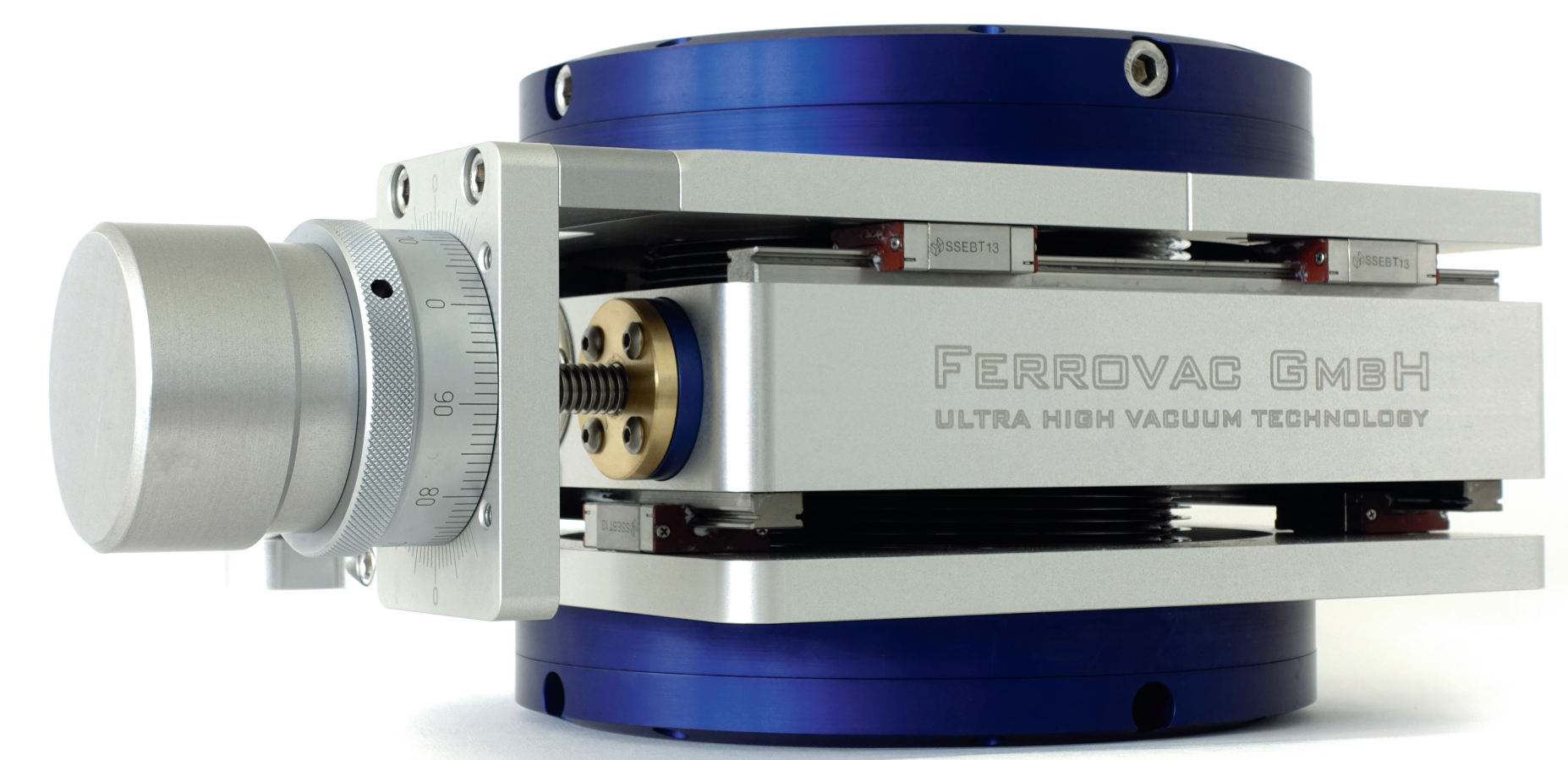

Example of sample environment with rotateable and tiltable sample stage with receiver for SHOME13 sample plates with electrical contacts