

# SWISSFEL :: ENERGY COLLIMATOR

The energy collimator presented here was developed for the Swiss Free Electron Laser facility (SwissFEL) in close collaboration with the Paul Scherrer Institute. It consists of four magnetic dipoles with a collimator block system installed between the two central dipoles. The energy collimator acts as a filter to protect the undulator line from parasitic electrons. In order to vary the energy acceptance of the system, two motorized linear drive units move the shielding blocks along the horizontal axis perpendicular to the direction of the e-beam.

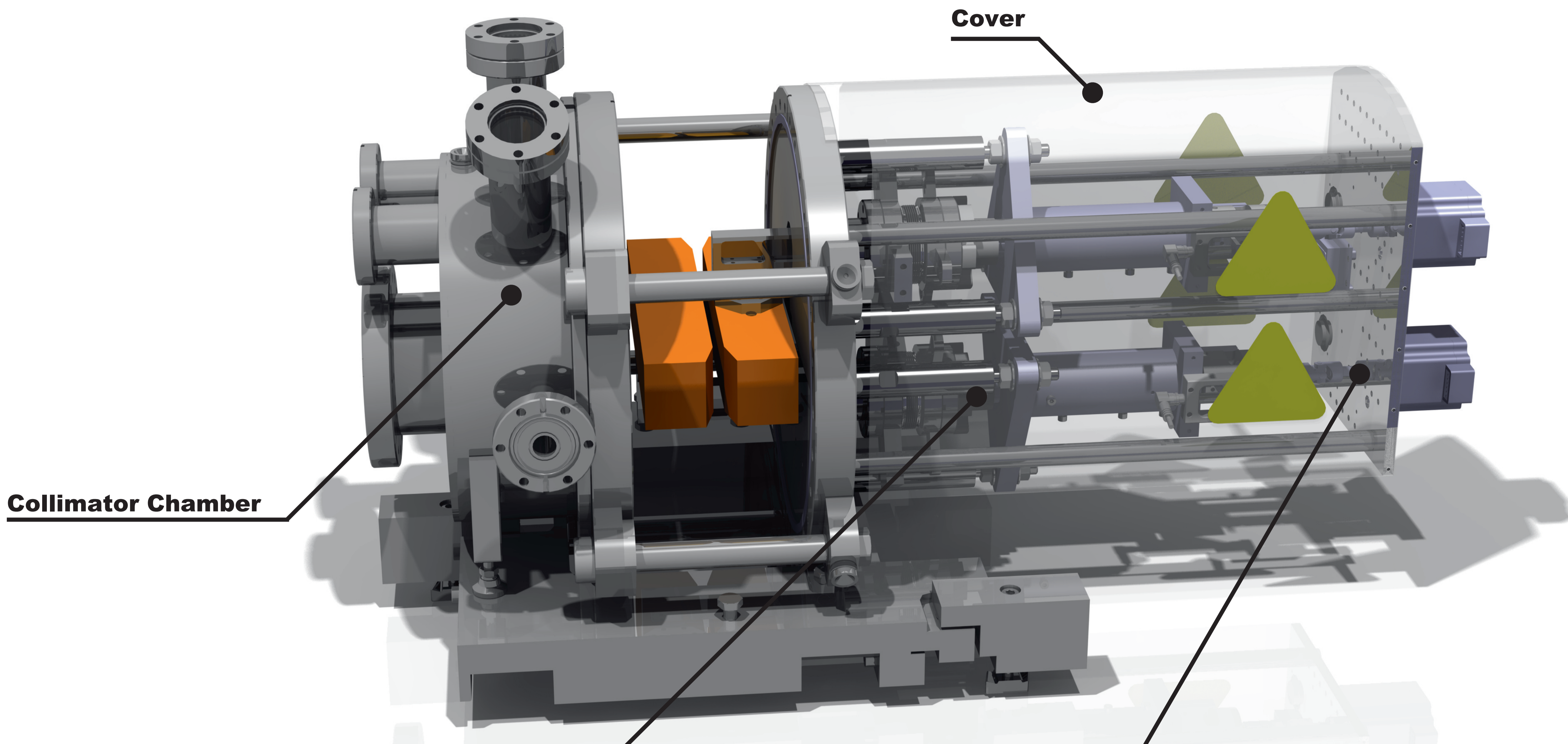

### Alignment Units

compensate mechanical stress due to angular errors

In order to resolve mechanical stress in the process of opening/closing the gap with the linear drives, possible angular errors are compensated by the alignment units.

These consist of massive triangular plates held by three sturdy steel studs which are used for the initial alignment.

The edge welded belows allow for the necessary angular freedom.

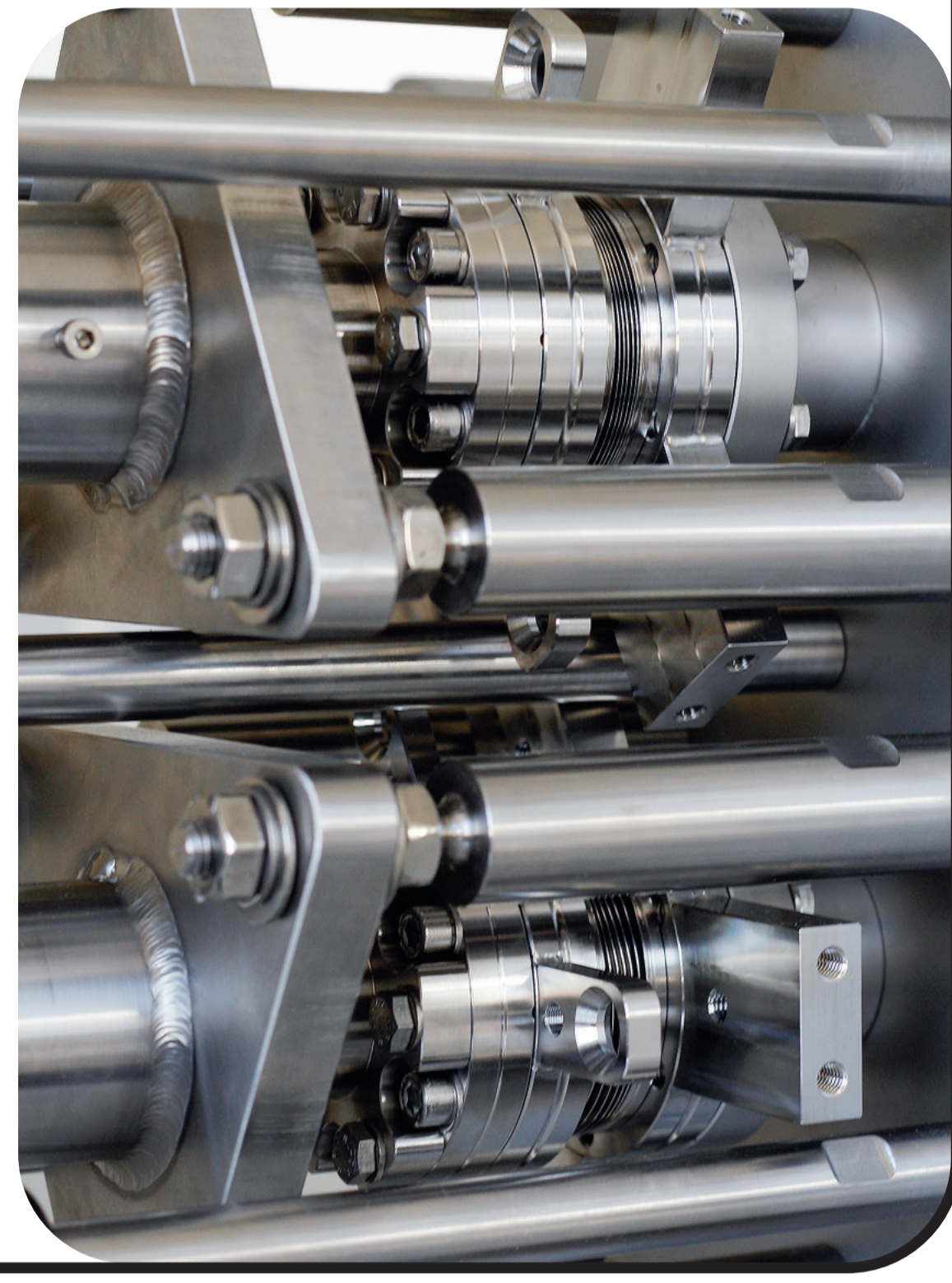

### Linear Drive Units

control the gap between the copper jaws.

Due to potential electromagnetic disturbances caused by the stepper motors, these are placed 0.5 m away from the electron beam axis.

With an accuracy of less than 1 micron, an integrated linear encoder measures the linear displacement of the alignment unit.

Linear force is transmitted via torque shafts to protect the alignment units' belows from distortion.

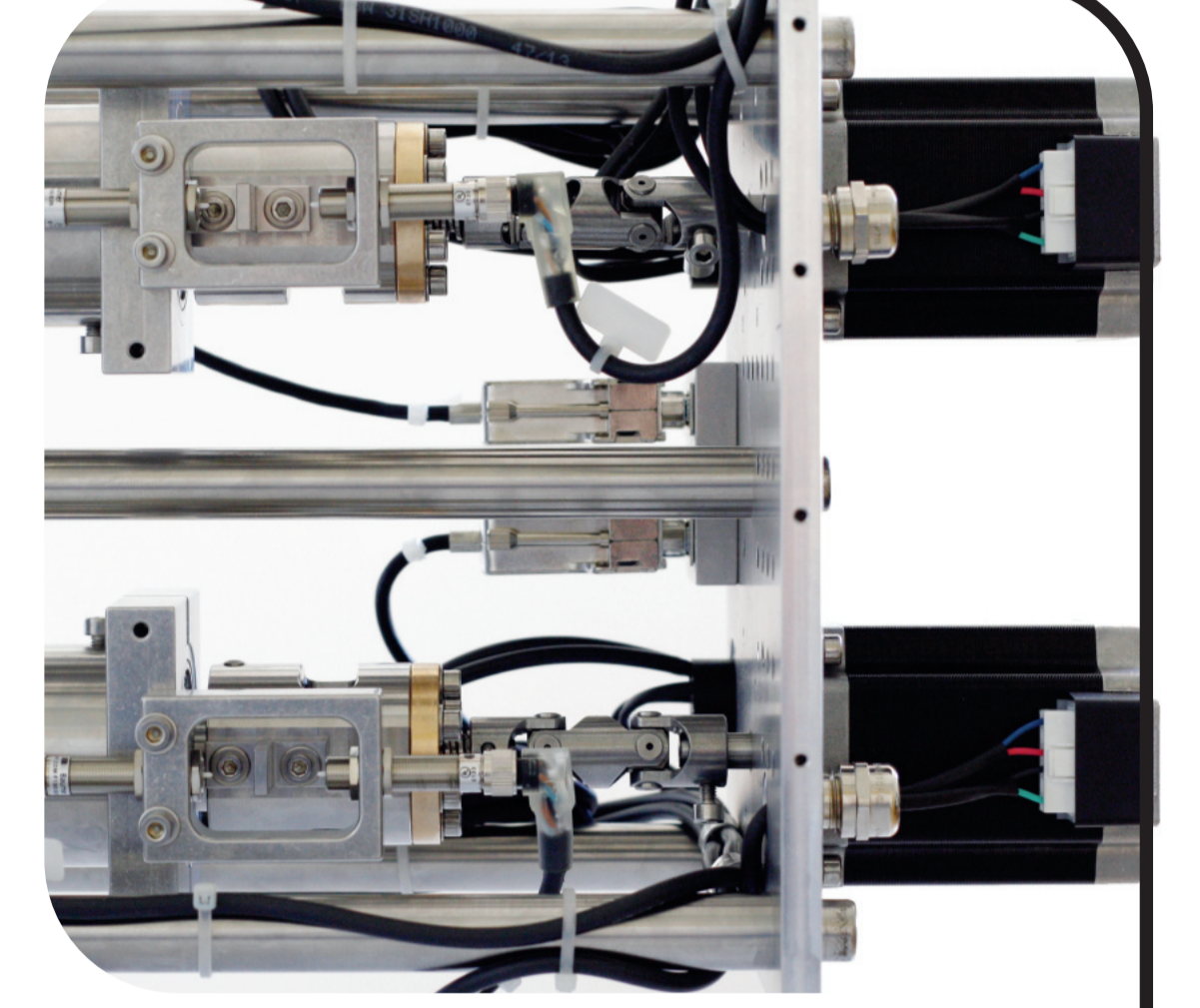

### Energy Collimator Location

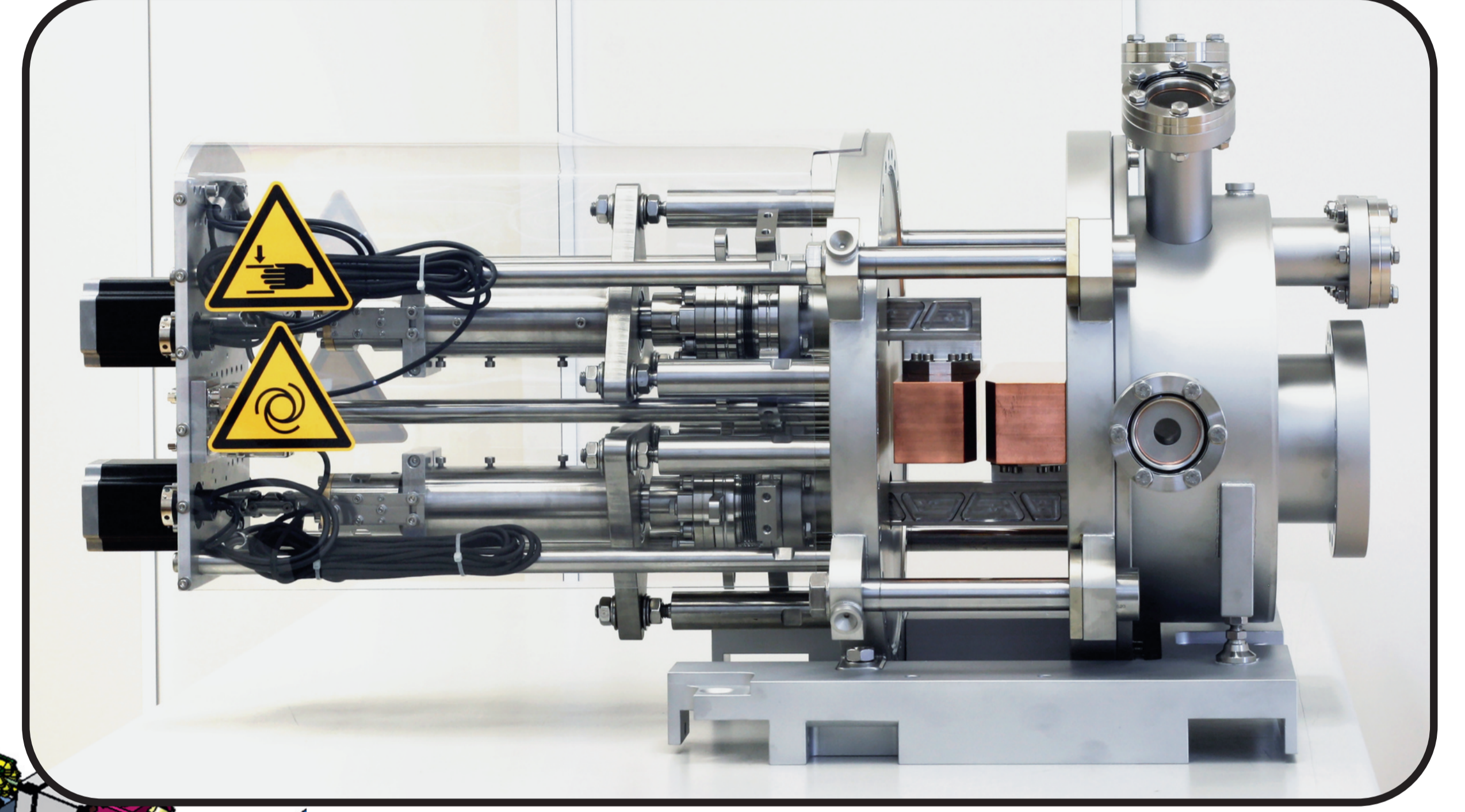
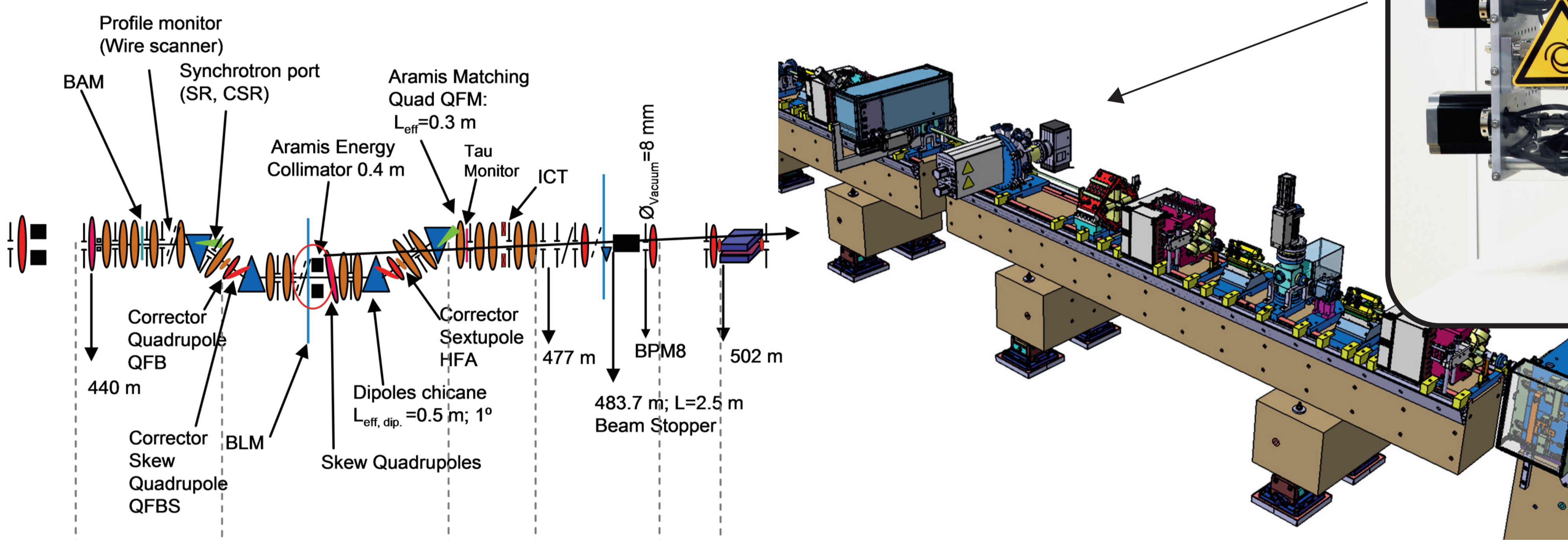

### Specifications

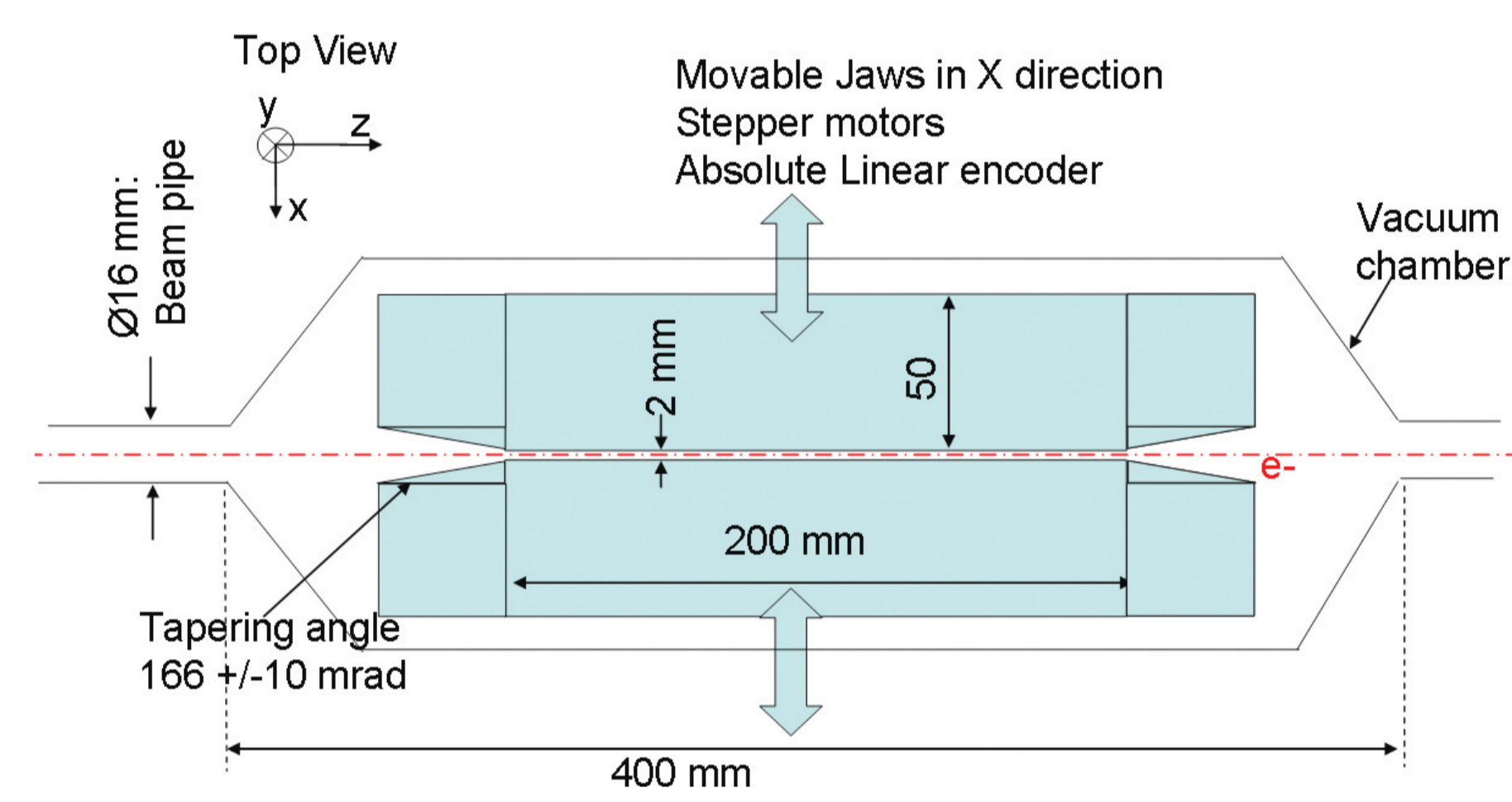

- Gap min: 0 mm
- Gap max: 16 mm
- Gap steps: <math><10 \mu\text{m}</math> (0.07% in energy)
- Surface roughness: Ra 0.2  $\mu\text{m}$
- Flatness: 100 nm
- Angle tolerances of each jaw
  - Yaw  $\phi$ : 0.5 mrad
  - Pitch  $\theta$ : 5 mrad
  - Roll  $\psi$ : 5 mrad



### Ferrovac Synchrotron Radiation Instrumentation:

- Portable UHV Suitcases
- Portable SPMs in UHV Suitcases
- Energy Collimators for Linear Accelerators
- Photocathode Load Lock Systems
- Custom UHV Chambers and Systems
- Sample Handling Solutions
- UHV Engineering

SWISS UHV TECHNOLOGY SINCE 1996