

WM :: WOBBLESTICK MANIPULATORS

The magnetically driven wobblestick manipulators are particularly designed for delicate and precise manipulations in ultra high vacuum systems.

In opposition to customary products, the motion of the shaft is not affected by the difference between atmospheric pressure and ultra high vacuum. Therefore, the shafts of the wobblesticks can be guided by the operator in a smooth and controlled way. In addition to the linear and angular motion, the shaft can be rotated continuously.

Specifications

- linear travel: 100mm, 150mm, 200mm, 250mm, 300mm or customized
- angular deflection +/-20 degrees (WA-models: +/-28 degrees)
- linear force: 30N (HT-models: 60N)
- torque: 0.5Nm (HT-models: 1Nm)
- bakeout temperature: 150deg C max.
- pressure range $1 \cdot 10^{-11}$ mbar to 1000mbar
- fully UHV compatible materials

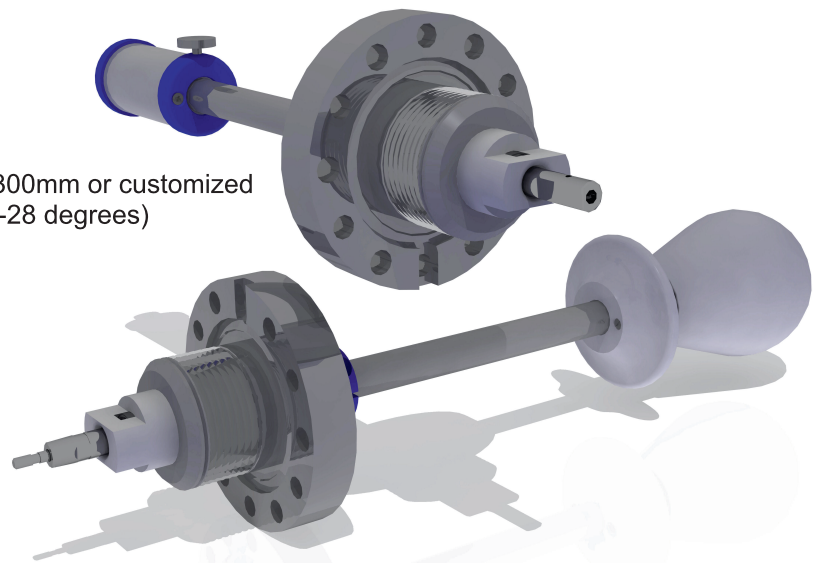

WMG40 Dual Shaft Wobblestick Manipulator

Dual shaft wobblestick manipulators are designed to operate a pincer grip. Slight pressing of the two halves of the knob against each other, will open the pincer.

The fine control (FC) magnetic coupling allows an even more precise control of pincer operation by turning a thumbwheel.

A variety of pincers are available for any know type of sample holder.

Ask for tailored jaws if your application is unique.

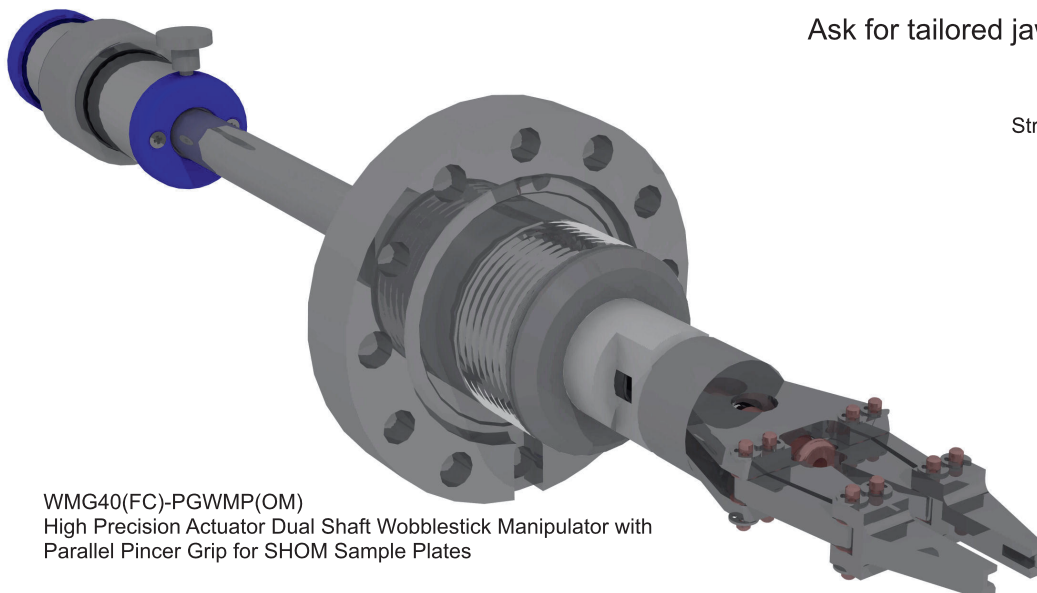

WMG40(FC)-PGWMP(OM)
High Precision Actuator Dual Shaft Wobblestick Manipulator with
Parallel Pincer Grip for SHOM Sample Plates

PGWMS(OM)
Straight Pincer Grip for SHOM Sample Plates

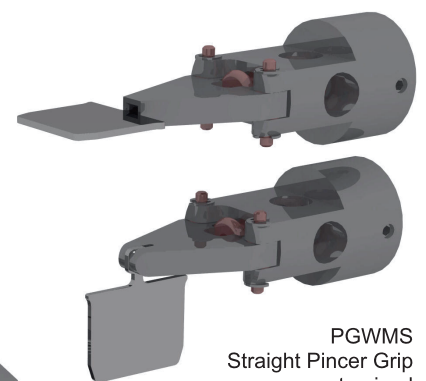

PGWMS
Straight Pincer Grip
customized

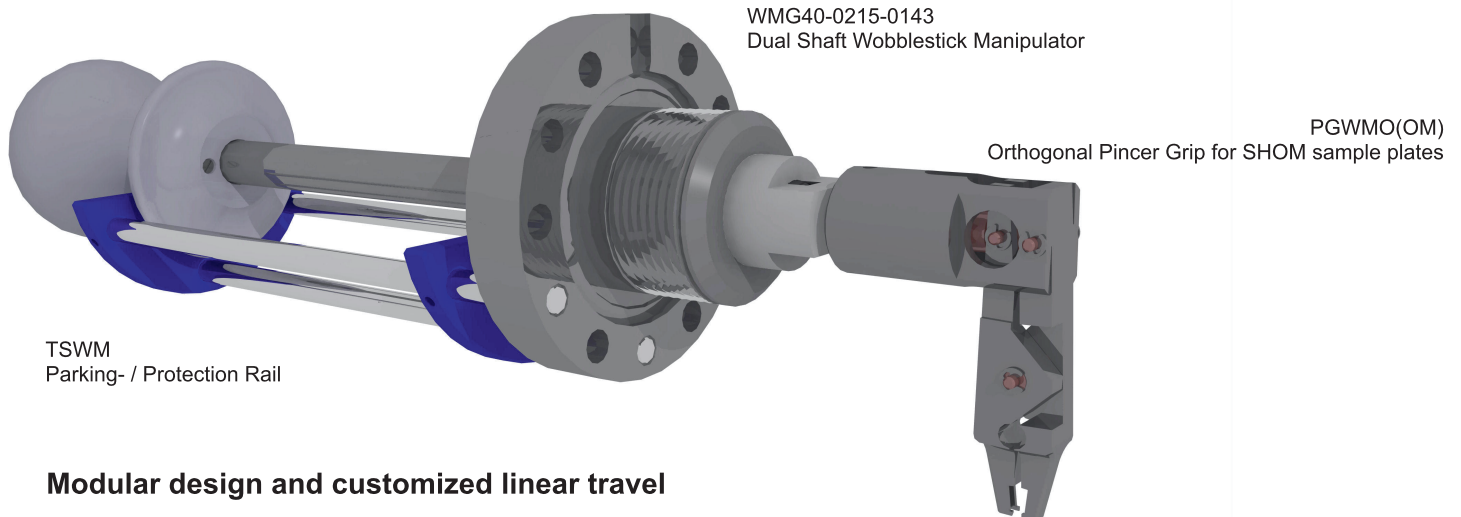

WMG40-0215-0143
Dual Shaft Wobblestick Manipulator

PGWMO(OM)
Orthogonal Pincer Grip for SHOM sample plates

TSWM
Parking- / Protection Rail

Modular design and customized linear travel

Example of an WMG40 Manipulator configured as a direct replacement for the Omicron STM1

WMG40-0215-0143-PGWMO(OM)-TSWM

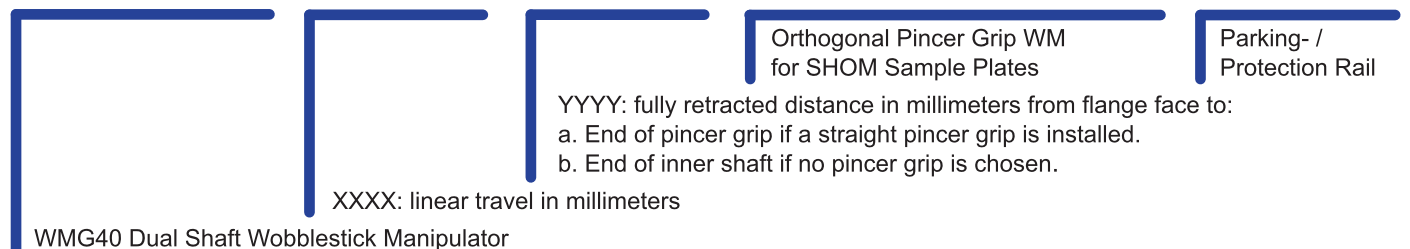

WM40 Single Shaft Wobblestick Manipulator

Single shaft wobblestick manipulators can be used with simple forks for sample exchange or as a screwdriver, to tightly lock sample holders in their dedicated position (1Nm with high torque option).

WM40-FRKBS
Single Shaft Wobblestick Manipulator with
Straight Fork for Block Style sample holders

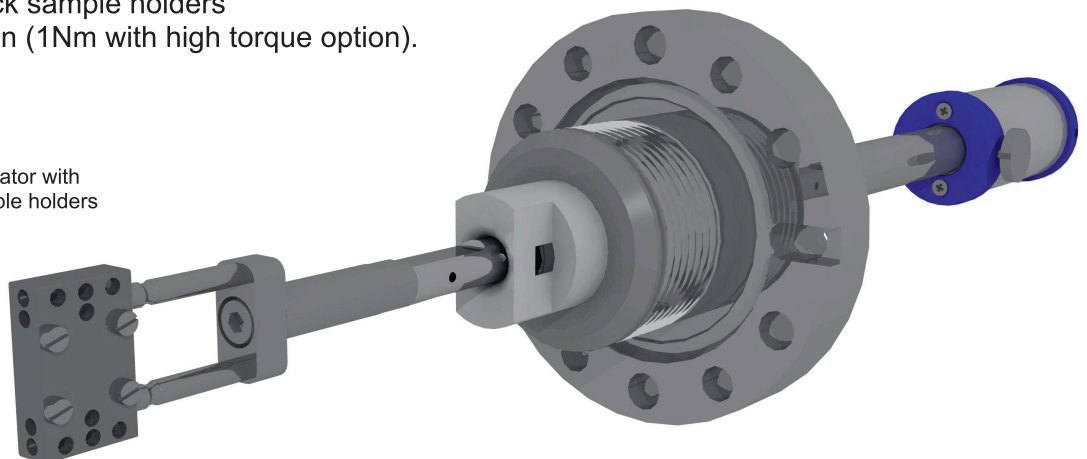

WMWA40 & WMGWA40 Wide Angle Wobblesticks

WA-models allow for an extended angular deflection of +/-28 degrees.

TSWM Parking- / Protection Rail for Wobblesticks

Wobblesticks require special care to be taken, so that the operators do not accidentally bend the tube while the wobblestick is not in use.

The removable parking rail supports and protects the shaft of the wobblestick.