

NEG/ION UHV SUITCASE

VSNH40 :: UHV Suitcase with NEG/Ion pump, DN40CF

The use of combined Non Evaporable Getter (NEG)/Ion-pump technology allows to build a truly portable, at the same time fully featured, compact and lightweighted UHV system. The weight (2.2kg) of the NEG/Ion pump used being less than one third of a 20lt/s ion pump, its nominal pumping speed is five times bigger (100lt/s).

The NEG-element can be activated with any standard DC lab power supply. High voltage for the ion-pump element is delivered by our rechargeable battery driven power supply LSA2.

The type and travel range of the transfer arm, as well as the sample grabbing mechanism, can be individually configured.

Ready to use:
Ferrovac UHV suitcases are
factory baked and delivered
under vacuum

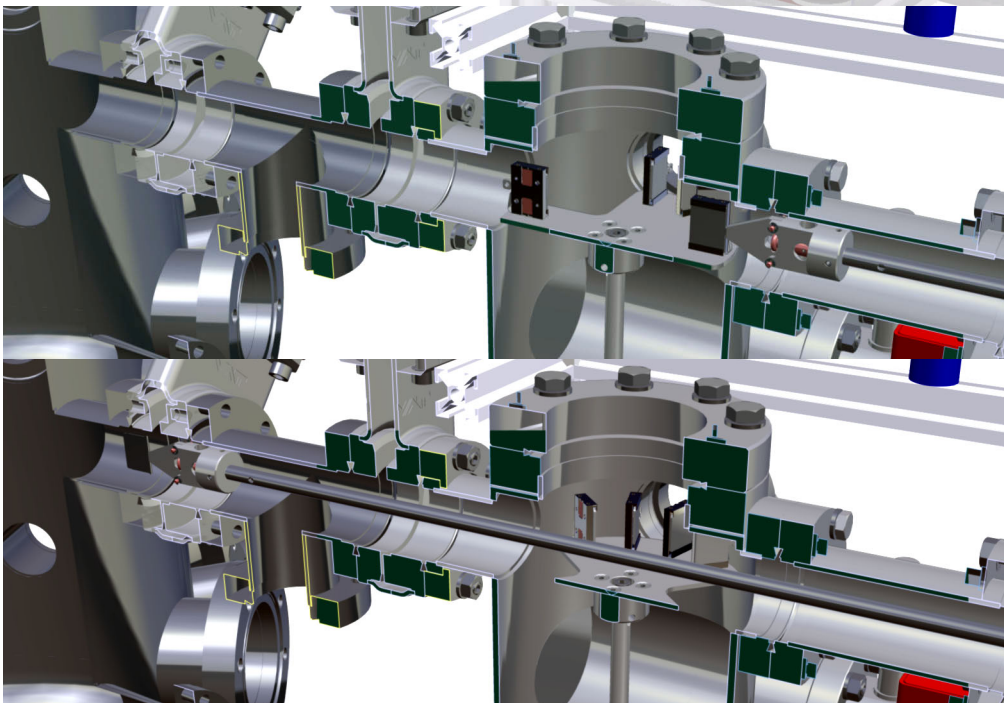
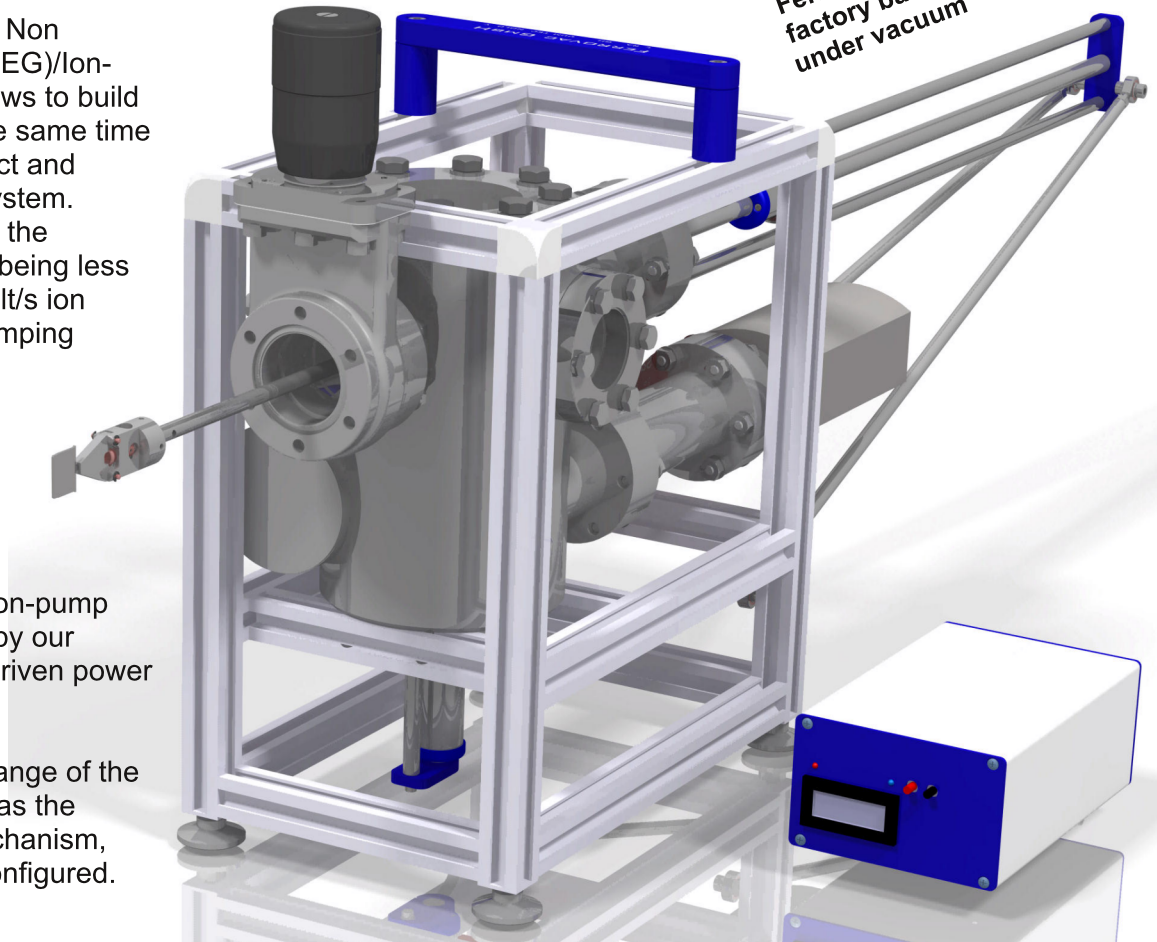

A key feature of the VSNH40 is the option to install a revolving storage platform for multiple samples. This allows the user not only to transport just one sample at a time, but also to store a larger number of samples under true UHV conditions and to exchange several samples at once.

Vacuum is measured using a Bayard-Alpert/Pirani full range gauge with integrated LED-display.

VSNH40S :: Ultra Compact UHV Suitcase with NEG/Ion pump, DN40CF

With the VSNH40S and S2 models, we are exploring the limits of compactness while at the same time reducing cost. Chamber geometry is minimized and only essentially important flanges are kept. Vacuum is measured by monitoring the current of the ion pump element.

Configuration example 1

VSNH40S2	Ultra compact UHV suitcase V2 with NEG/Ion pump
WMG40(FC)	High precision actuator dual shaft wobblestick
PGWMS(OM)	Straight pincer grip for SHOM sample plates
TSWMA	Set screw adjustable angular aligner
TSWMF	revolvable protection rail

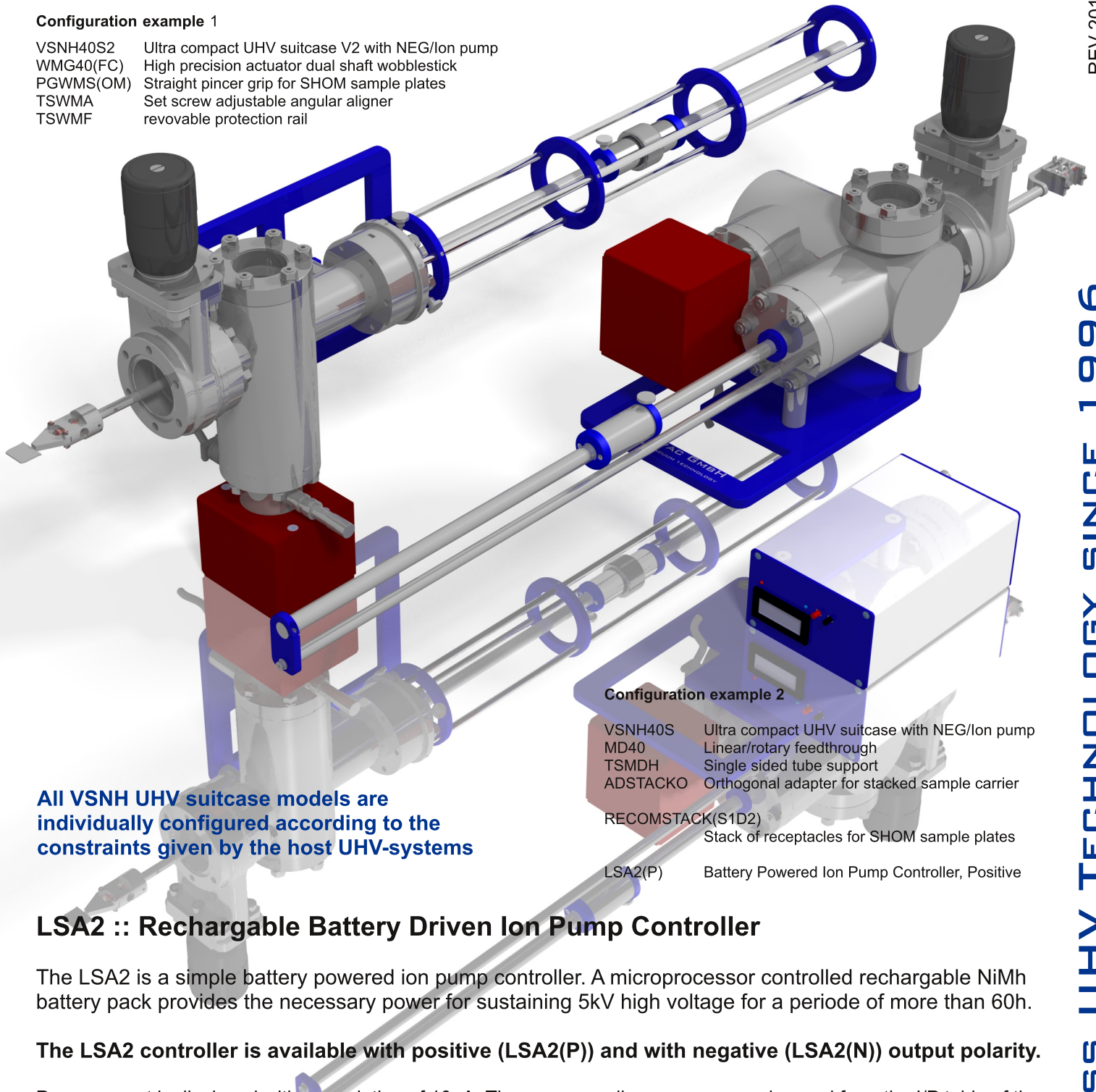

Configuration example 2

VSNH40S	Ultra compact UHV suitcase with NEG/Ion pump
MD40	Linear/rotary feedthrough
TSMDH	Single sided tube support
ADSTACKO	Orthogonal adapter for stacked sample carrier
RECOMSTACK(S1D2)	Stack of receptacles for SHOM sample plates
LSA2(P)	Battery Powered Ion Pump Controller, Positive

All VSNH UHV suitcase models are individually configured according to the constraints given by the host UHV-systems

LSA2 :: Rechargeable Battery Driven Ion Pump Controller

The LSA2 is a simple battery powered ion pump controller. A microprocessor controlled rechargeable NiMh battery pack provides the necessary power for sustaining 5kV high voltage for a periode of more than 60h.

The LSA2 controller is available with positive (LSA2(P)) and with negative (LSA2(N)) output polarity.

Pump current is displayed with a resolution of 10nA. The corresponding pressure can be read from the I/P table of the pump manufacturer. The NEG element of NEG/Ion pump needs activation by heating it up to a temperature of 500°C. The pump features an integrated heater. After activation, the NEG pump does not need any electrical power supply.